

MAS403 BT
(JIS B6339) AD
BT50 NORM

SOĞUTMA DELİĞİ x 2 ADET
COOLANT HOLE x 2 PIECE

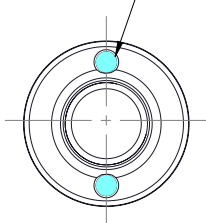
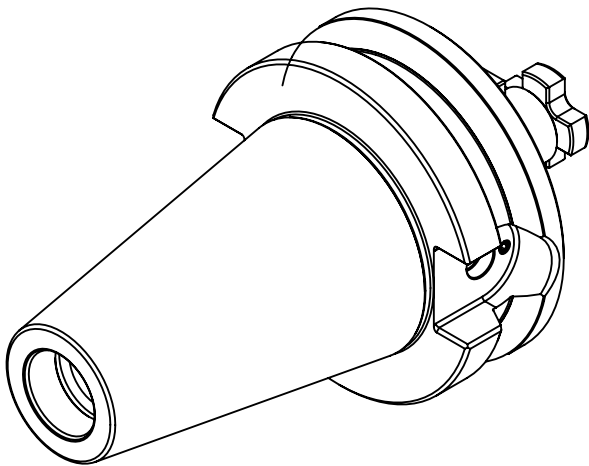

İÇTEN SOĞUTMALI ALIN KAMALI MALAFA SHELL MILL HOLDER INTERNAL COOLANT	TARAMA BAŞLIĞI SIKMA CİVATASI(DIN 6367) DRAW IN BOLT(DIN 6367)	VIDALI KAMA DRIVE KEY															
		<table border="1"> <tr> <td>b</td> <td>h</td> <td>L</td> </tr> <tr> <td>10</td> <td>11</td> <td>11,2</td> </tr> </table> DIN 912(ISO 4762) 8.8	b	h	L	10	11	11,2									
b	h	L															
10	11	11,2															
	<table border="1"> <tr> <td>M</td> <td>M10</td> </tr> <tr> <td>D</td> <td>28</td> </tr> <tr> <td>K</td> <td>7</td> </tr> <tr> <td>L</td> <td>18</td> </tr> </table> 	M	M10	D	28	K	7	L	18		<table border="1"> <tr> <td>MxL</td> <td>SW</td> <td>Max.Clamping Torque (N.m) Maks.Sıkma Torku (N.m)</td> </tr> <tr> <td>M4x12</td> <td>3</td> <td>2.5~3.3</td> </tr> </table>	MxL	SW	Max.Clamping Torque (N.m) Maks.Sıkma Torku (N.m)	M4x12	3	2.5~3.3
M	M10																
D	28																
K	7																
L	18																
MxL	SW	Max.Clamping Torque (N.m) Maks.Sıkma Torku (N.m)															
M4x12	3	2.5~3.3															
	Ürün Adı Product Name	MAS403 BT(JIS B6339) BT50 AD SHELL MILL HOLDER ALIN KAMALI MALAFA	Ürün No Product No														
			505.11.22.55														
			Üretim No Production No														
			80030306														

Bu dokümanın tüm hakları EROGLU MAKİNA A.Ş.'ye aittir.
All rights of this document belongs to EROGLU MAKİNA A.Ş.